

Solidilite V & Sublite V

Powerful and efficient light polymerisation

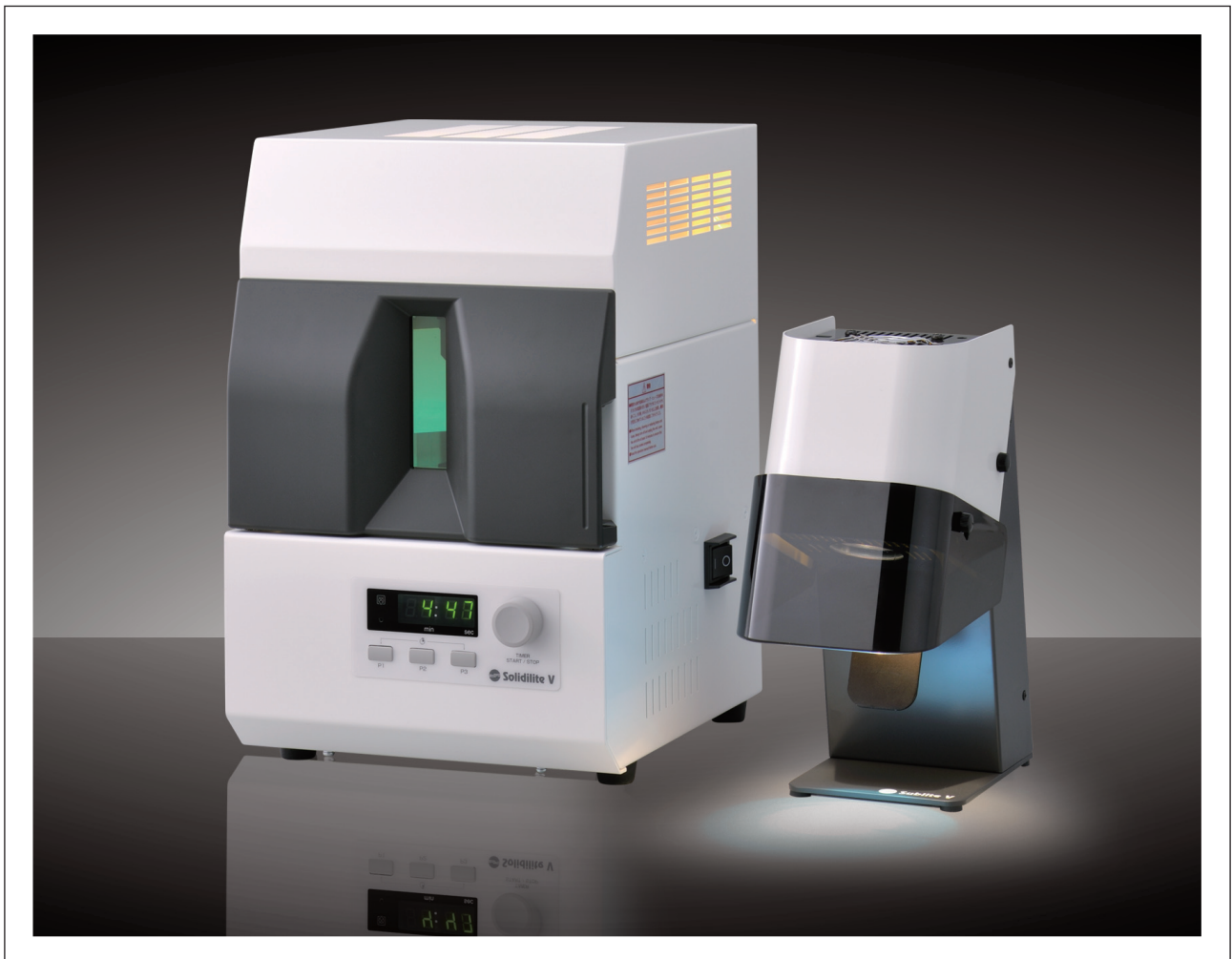

POWERFUL · COMPACT · SIMPLE · EFFICIENT

The newly developed **Solidilite V** & **Sublite V** light polymerisation units will impress you with the help of their state-of-the-art technology. You will appreciate their compact construction and appealing design.

They are designed to optimally polymerise the ceramic-filled micro-hybrid composites CERAMAGE and SOLIDEX, and boost the efficiency of the working process when used either separately or in combination.

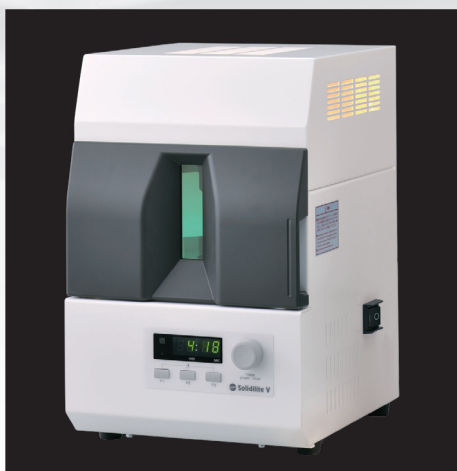

Solidilite V

With an extraordinarily high light output of 600 W and an effective heat conduction exchange, the **Solidilite V** guarantees gentle curing which is appropriate for the material involved, with a short exposure time.

Compact and efficient at 400 - 550 nanometres

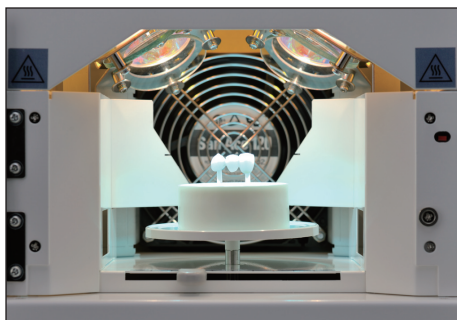

Four powerful halogen lamps, 150 W each with a light wave spectrum of 400-550 nanometres, guarantee efficient curing in the compact polymerisation chamber.

The height-adjustable turn table provides shadow-free exposure to light due to an ideal alignment of the restorations to the light source.

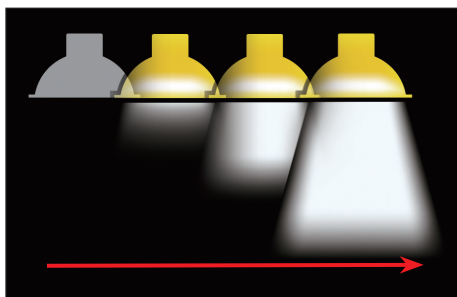

Soft-start cure assures longer bulb life

Polymerisation in the **Solidilite V** starts very gently. The halogen bulbs will reach full power after 2 to 4 seconds.

The duration of performance and intensity of the bulbs are greatly extended with this soft start function.

Individually programmable

Three light exposure programmes enable efficiency in use:

P1 - 1 minute ■■■ **P2 - 3 minutes** ■■■ **P3 - 5 minutes**

You just turn and press the programmable timer key to change the polymerisation times in intervals of 10 seconds and adjust to each user's needs or the specifications of various composite manufacturers.

The display tracks the operating hours of the unit and is also equipped with a warning light to keep you informed about the readiness of the four halogen bulbs.



Sublite V

Time-saving and professional pre-polymerisation

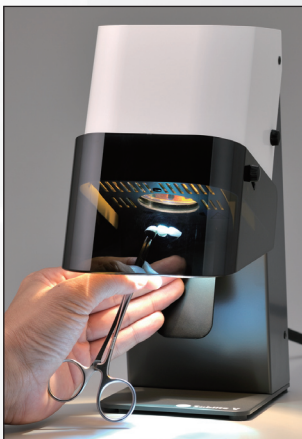

The powerful **Sublite V** is just the right complement to your **Solidilite V** light-curing system as it saves valuable time and assures efficient polymerisation. The 150 W halogen lamp's efficient performance enables you to pre-polymerise an applied composite layer in just 5 seconds per tooth.

Keeping the one-touch-switch pressed starts a second programme for larger restorations with a maximum curing time of 20 seconds.

Its convenient one-hand operation and spacious curing area below the light guard also enables you to correctly position the restoration on the working model.

A variety of settings

The individual settings of the **Sublite V** are just as diverse as each working technique. The light guard can be set horizontally and vertically depending on the direction of rotation so that it always guarantees non-glare polymerisation of the objects, perfectly matching your personal application needs.

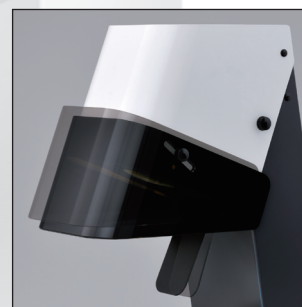

Technical Data

Solidilite V

- Dimensions: W 230 mm x D 252 mm x H 354 mm
- Weight: approx. 9.5 kg
- Rated supply voltage: 200 V-240 V, 50/60 Hz
- Fuse: 2 x 3.15 A time-lag
- Lamp: 4 JCR 110V 150W halogen lamps
- Spectral range: 400-550 nm

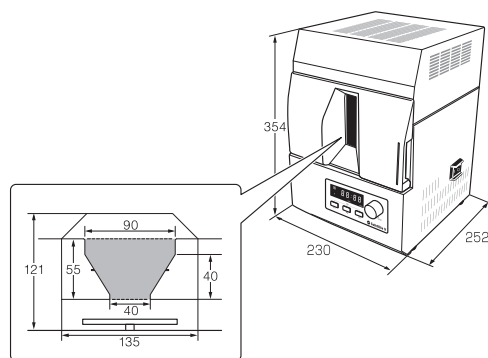

Sublite V

- Dimensions: W 112 mm x D 210 mm x H 252 mm
- Weight: approx. 2.5 kg
- Rated supply voltage: 200 V-240 V, 50/60 Hz
- Fuse: 2 x 1.6 A time-lag
- Lamp: 1 JCR 110V 150W halogen lamp
- Spectral range: 400-550 nm

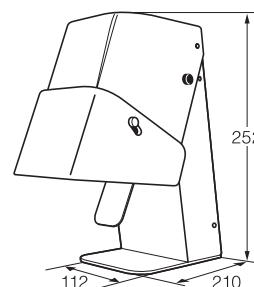

Accessories

Post Stand P

Dimensions: \varnothing 60 mm / H 23.5 mm
 With the two crossing central ditches and more than 100 holes, this tray offers extraordinarily quick and easy positioning of objects with the matching pins, ranging from single crowns to 14-segment bridges.



Post Set

3 pins each in 5 forms
 can be individually shaped / anterior sharp /
 anterior flat
 premolar oval / molar round

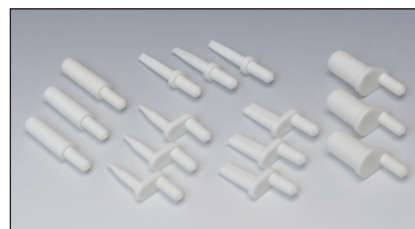

Ordering information

Solidilite V with accessories	PN 5106
Sublite V	PN 5108
JCR 110V 150W halogen lamp	PN 5610
Post Set (anterior / posterior holding pin set)	PN 5058
Post Stand P	PN 5059



SHOFU INC. 11 Kamitakamatsu-cho, Fukuine, Higashiyama-ku, Kyoto 605-0983, Japan (www.shofu.co.jp)
 SHOFU INC. Singapore Branch 10 Science Park Road, #03-12 The Alpha, Science Park II, Singapore 117684 (www.shofu.com.sg)
 SHOFU DENTAL TRADING (SHANGHAI) CO., LTD. No. 645 Jiye Road, Sheshan Industrial Park, Songjiang, Shanghai 201602, China (www.shofu.com.cn)
 SHOFU DENTAL CORPORATION 1225 Stone Drive, San Marcos, CA 92078-4059, USA (www.shofu.com)
 SHOFU UK Riverside House, River Lawn Road, Tonbridge, Kent, TN9 1EP, UK (www.shofu.co.uk)
 SHOFU DENTAL GmbH  Am Brüll 17, 40878 Ratingen, Germany (www.shofu.de)
 SHOFU is a registered trademark of SHOFU INC. All other trademarks and registered trademarks are the property of their respective holders. SHOFU INC. reserves the right to change specifications without notice.
 © Copyright 2001 SHOFU INC. All rights reserved.